

# PRONOVA 525



*Packaging the way you want it  
Flexible, cost-efficient & convenient*

The Pronova 525 is a robust and highly efficient bag packaging machine that is mainly designed for 24-hour-use in automatic packaging lines. The optional supporting conveyor allows for also heavy products to be packaged, vertically or horizontally. The machine has proven to be reliable in tough environments.

The opening rails keep many bags open at a time for filling. By simply turning two knobs you can instantly and very easily change the bag opening and adjust it to the product's size and shape – from a very narrow and thin up to a square opening.

## Filling options

The 525 can be integrated with most weighing systems, volume fillers and product counters. With a continuous product flow from a production unit. Pronova can supply for a product counter and equipment that collects the product while pulling a new bag in position.

## PLC system

The machine is equipped with a PLC system. The operator panel gives all necessary machine information and its touch-button display with universal symbols is highly operator-friendly.

## Flexibility

- Versatile design - easily adjusted to fit products and productions.

- Opening arms can be up to 5 meters long.
- Bag width - 50 - 800 mm.
- Bag features - reclosability, perforation, hanger holes, stand-up pouch, reinforced headers etc.
- Materials - PE, PP, laminates.
- Continuous or intermittent bag feed.

## Standard

- Preset counter for automatic stop after preset number of bags.
- Intermittent bag feeding with adjustable stop position.
- Preset counter for numbers of bags per feed.
- Continuous feeding of bags.
- Out- and inputs for communicating with automated lines.
- Speed control for bag feeding.

## Options

- Supporting conveyor belt
- Imprinters
- Labellers
- Product counter
- Compressing unit
- Modem
- Recipe management
- Zipperopener/closer
- MAP (modified atmosphere)



## Technical description

The length of the opening arms can be made between 1 - 5 meters, depending on chosen filling method.

Bags can hang free, without support, up to a weight of 300-400 grams per 100 mm bag width. For heavier products, we recommend the optional conveyor belt.

### 525 standard

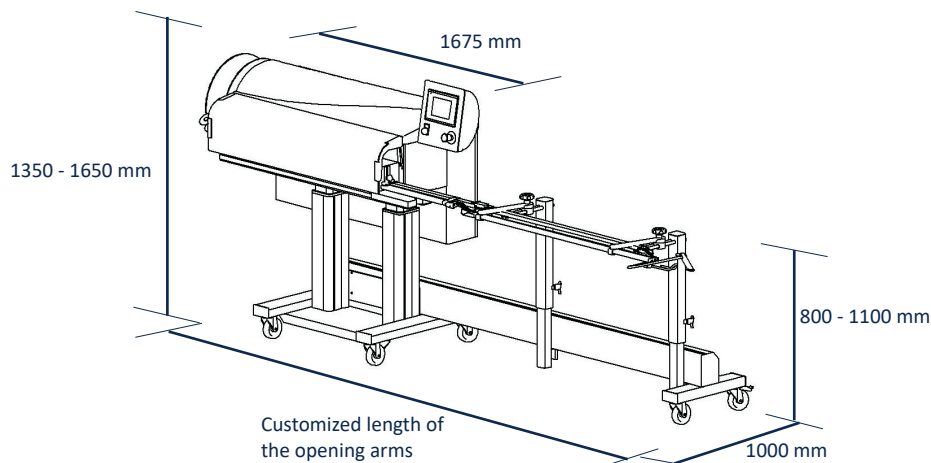

### 525 with conveyor belt

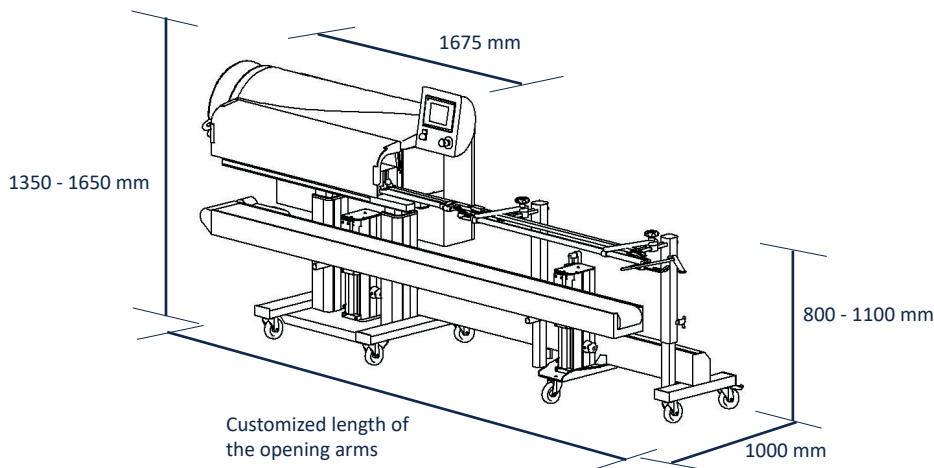

## Technical specifications Pronova 525

Machine weight: .....	300 kg
Standard sealing speed: .....	12 m/min
Power: .....	2,5 kW
Electrical supply: .....	400 V 3-phase
Compressed air: .....	600 kPa, 0,06 m <sup>3</sup> /h

## Quality & Safety

The Pronova packaging system stands for quality, safety and accountability.

Every part of the business complies with the standards set by ISO 9001 from the time we begin the design and production of machines and packaging to delivery, service, education and support.

Our plastic factory is certified in accordance with ISO 22000

All machines are CE marked.

The Pronova packaging machines are designed with few moving parts and with a simplicity that makes them easy to use and easy to maintain. The welding unit is easy to disassemble without the use of any tools.

Our distributors and licensees around the world all take responsibility for the supply of machinery and materials, and they are all well trained for installation, training and service of our machines.



For further information, don't hesitate to contact us:

Pronova AB  
Olofsdalsvägen 26  
302 41 Halmstad  
Sweden

Tel: +46 (0)35 17 19 00  
sales@pronovaab.se  
www.pronovasweden.eu

**PRONOVA**  
PACKAGING SYSTEMS



CERTIFIED  
ISO 9001  
Quality management systems



CERTIFIED  
ISO 22000  
Food safety  
management systems

